



STR240 STR Periscope

- 20% Higher Capacity
- Very Compact Integration
- Suitable for Crystallization

STR240

The STR is the most versatile incubator in the market. Fits underneath any work-station or liquid handling system. Reduces your bottlenecks by 50%, when using multiple plate transfer nests. You optimise your budget because you do not have to buy extended or articulating robotic arms. 240 Plate capacities in such a foot print is cutting edge technology.

The periscope delivery shovel presents the plate to the top of the work surface. With work space at a premium, the STR will save valuable space for other components above your system and gives you a more aesthetically pleasing compact appearance. All this without sacrificing price.

Access through full-sized user door

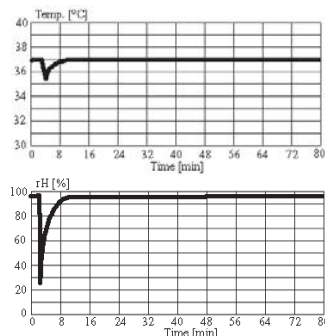

Access through the small robotic gate

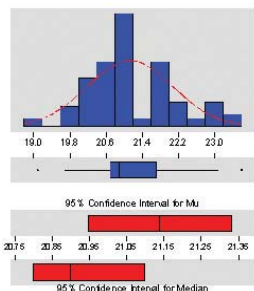
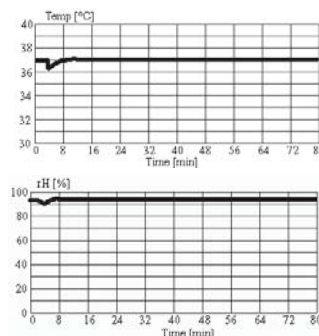

The average Access time is 21.1 seconds

| Climate Options | | | | |
|---------------------------|-----------------|----------|---------------------|------------|
| | Temperature | Humidity | Description | Order Nr. |
| STR240-IC ¹⁾ | 33..50°C (70°C) | max. 95% | Incubator | 9143 00 91 |
| STR240-HC ¹⁾³⁾ | 04..25°C | max. 90% | Humid Cooler | 9143 00 92 |
| STR240-DC2 ¹⁾ | 04..25°C | 04..50% | Dry Storage | 9122 05 32 |
| STR240-HR ¹⁾³⁾ | 04..50°C (70°C) | 90..95% | Humid Wide Range | 9143 00 93 |
| STR240-DR ¹⁾²⁾ | 04..50°C | 02..80% | Dry Wide Range | 9122 05 30 |
| STR240-AR ⁴⁾ | 04..50°C | 10..95% | Humidity Controlled | 9143 01 96 |
| STR240-IC2 ¹⁾ | 33..50°C (70°C) | 20..95% | Humidity Heated | 9143 01 98 |
| STR240-DF | -20..20°C | 02..45% | Deep Freezer | 9122 05 29 |
| STR240-NC | - | - | No Climate | 9143 02 04 |

1) Humidity depends on temperature setting / 2) Humidity Adjustable / 3) Adjustable dehumidification / 4) Adjustable humidification

Options

| | Order Nr. | Gassing Option | Order Nr. |
|--|------------|-------------------------------|------------|
| High temperature 70°C capability | 9122 06 02 | Fast CO2 Gassing Option | 9118 11 12 |
| Bar Code Reader Option | 9118 11 03 | Fast N2 Gassing Option | 9118 11 13 |
| Plate Presence Sensor | 9121 00 62 | Fast O2 Gassing Option | 9118 11 14 |
| Disposal Tips upgrade kit up to 100mm height | 9118 12 23 | Additional CO2 Gassing Option | 9118 11 07 |
| Fast access for time critical applications | 9111 10 00 | Additional N2 Gassing Option | 9118 11 11 |
| N-Way Decontamination | 9122 05 28 | Additional O2 Gassing Option | 9118 11 08 |
| Liconel self decontaminating incubator chamber | 9143 01 97 | | |
| Linear Shaker, Amplitude 1-100mm, 12-300 rpm | 9143 02 00 | | |
| UCI Universal Communication Interface | 9118 11 17 | | |
| Steam Injection | 9118 11 16 | | |

Like all members of the StoreX Star family the STR240 can be equipped with a large number of further options and a wide selection of useful accessories. For details please visit www.liconic.com.

Dimensions

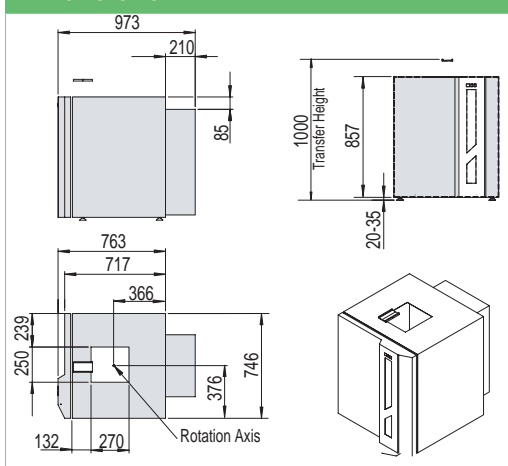

Capacity

| Plate Type | Plate Height | Plate capacity of unit |
|-------------------------|--------------|------------------------|
| NTP (Nanotiter Plates) | 5 mm | 462 |
| | 11 mm | 308 |
| MTP (Microtiter Plates) | 1536 | 297 |
| | 12 mm | 240 |
| | 17 mm | 187 |
| | 22 mm | 187 |
| | 23 mm | 187 |
| DWP (Deep Well Plates) | 24 mm | 187 |
| | 27 mm | 165 |
| | 44 mm | 110 |
| | 53 mm | 88 |
| DiTi200 | 66 mm | 77 |
| DiTi1000 | 104 mm | 44 |



www.liconic.com

Europe & International: Liconic AG, Liechtenstein

UK & Nordic: Liconic UK Ltd, Manchester

US & Asia: Liconic Inc, Woburn MA

22.05.2014

© Liconic AG